

PRODUCT MODELS*

- Evolution Cover
 - Oasis Cover
- *Specifically, the chains of the G3 generation jack (with a hole on the side of the jack).

PURPOSE OF THE REPAIR PROCEDURE

This repair procedure should be performed if the cover is “bouncing”.

PREPARATION

- Make sure the parts kit is complete and that parts have not been damaged during transport. Call your local dealer if parts need to be replaced.

- Gather the required tools, as seen in the table below.

TOOLS REQUIRED	
3/16" Allen key	52" long lumber
Hammer	Flat blade screwdriver

PARTS KIT NO. 236296			
1 x Magnet	1 x Pulley	1 x Hook	1 x Bolt
1 x Nut	1 x 1.32-lb Mass	1 x Corner bracket	1 x 8" Steel sling

Version française à la page 4.

⚠ WARNING

This procedure must be performed by a certified Covana installer.

Keep the key out of the key switch socket at all times. The certified Covana installer must keep control of the key during the repair procedure. Derogation from this directive could cause serious injury or damage the cover.

STEP BY STEP PROCEDURE

- 1) Raise the cover to its highest position.

- 2) Loosen the Phillips M6 x 20 mm screw at the bottom of one of the posts. **Do not remove the screw.**

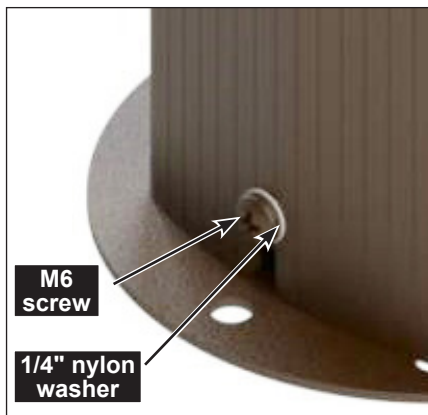

IMAGE 1

- 3) Pull up the sleeves of the post until the adjustment screw of the jack is accessible, and slide a 52" long lumber underneath the sleeves to hold them in place (see image 2).

NOTE

Each telescopic post is made of one jack and three sleeves.

⚠ WARNING

Slowly and gently pull up the sleeves to prevent injuries.

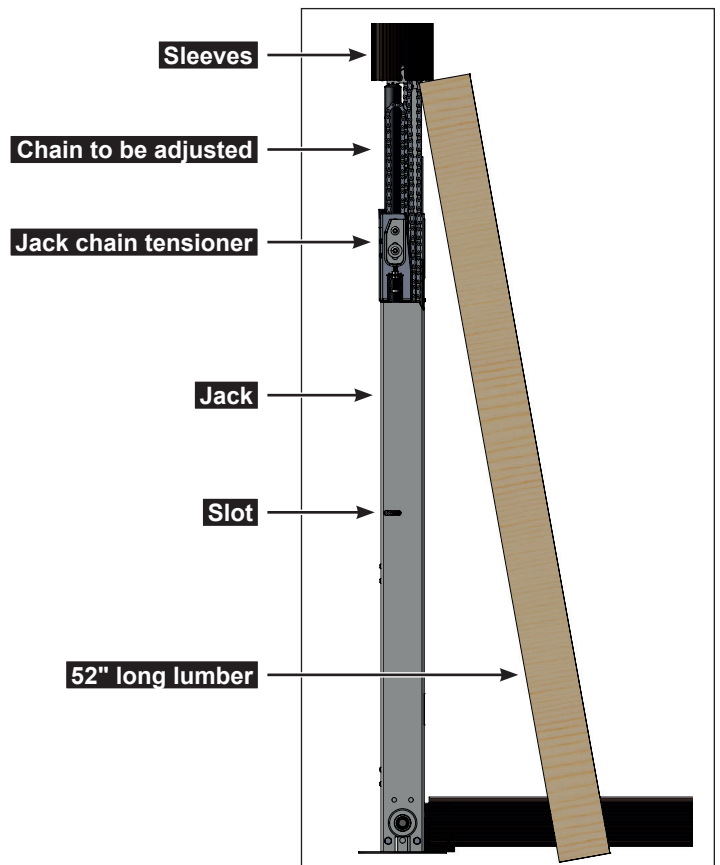

IMAGE 2

- 4) Untighten (DO NOT REMOVE) the carriage locking screw with a 3/16" Allen key (see image 3).

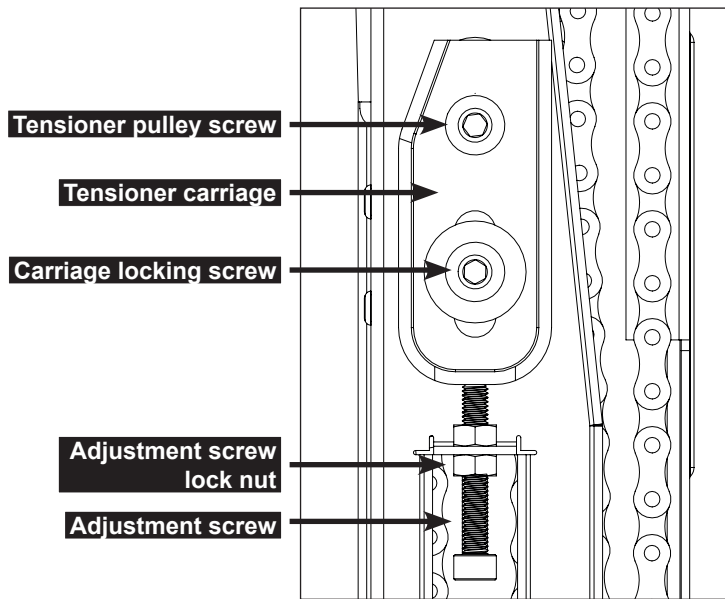

IMAGE 3

- 5) Loosen the adjustment screw lock nut (see image 3) to easily move the adjustment screw.
 6) Assemble the magnet, corner bracket, pulley and mass kit (see images 4-A, 4-B, 4-C, and 4-D). Using the pulley and mass kit, install the hook on the chain at the far side of the slot and let the mass slowly go down.

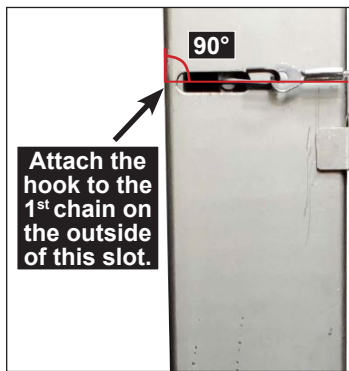

IMAGE 4-A

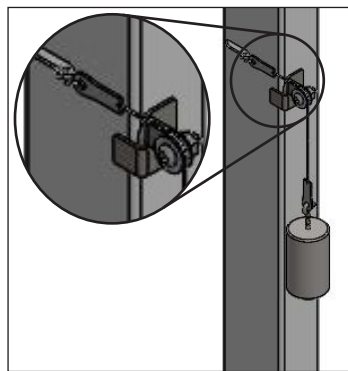

IMAGE 4-B

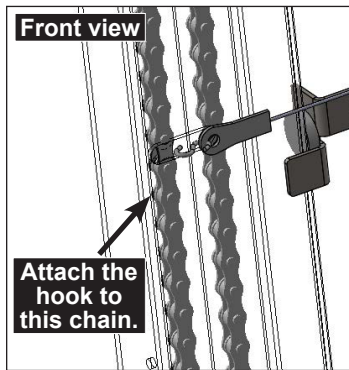

IMAGE 4-C

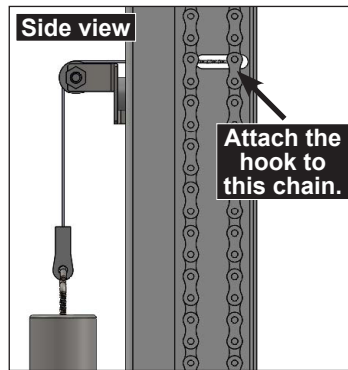

IMAGE 4-D

NOTE

To simplify the images, the gas spring has been hidden.

- 7) When the hook is attached to the chain, and the mass is free to go down, the right side of the chain must be aligned with the right side of the slot. Therefore, both edges must be tangent to each other (see red line in images 5-A and 5-C). If this alignment is not possible, the chain will need to be adjusted; see next steps.

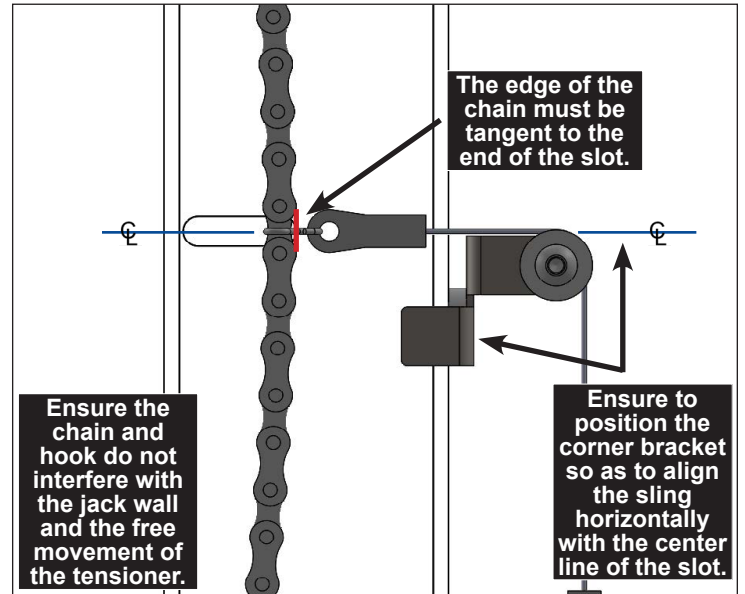

IMAGE 5-A

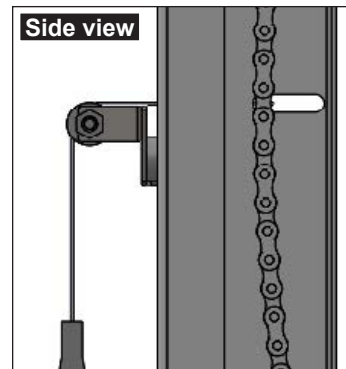

IMAGE 5-B

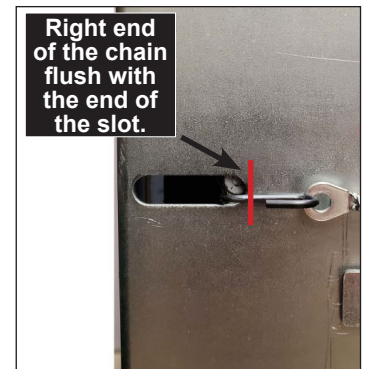

IMAGE 5-C

- 8) If the edge of the chain and the slot were not tangent in step 7, use a 3/16" Allen key to screw/unscrew the adjustment screw until the chain is tangent to the right side of the slot. The hook might touch the side wall of the post and interfere with its movements. To solve this issue, pull the mass up and down a few times until the whole system is in place.

⚠ CAUTION

When executing step 8, make sure that the magnet is low enough so that it doesn't touch the steel sling, to prevent it from interfering with the movement and adjustment (see image 6).

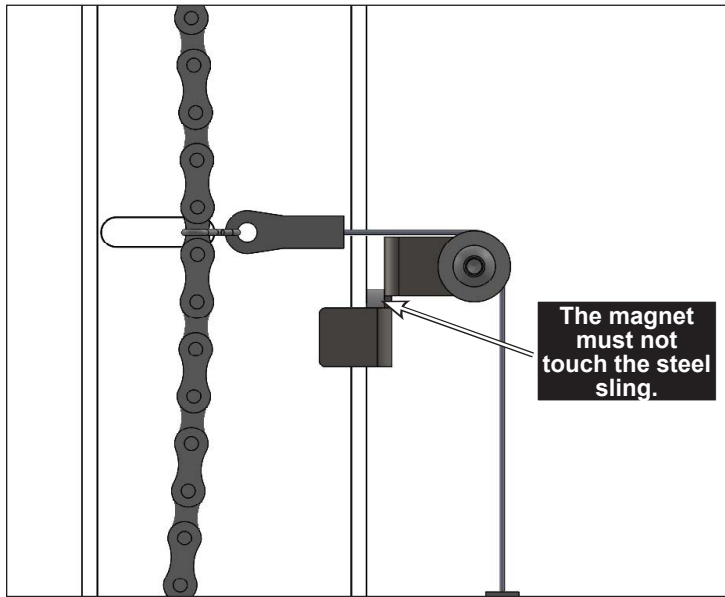

IMAGE 6

⚠ WARNING

When executing step 8, ensure the adjustment screw doesn't go underneath the carriage plate of the tensioner (see image 7).

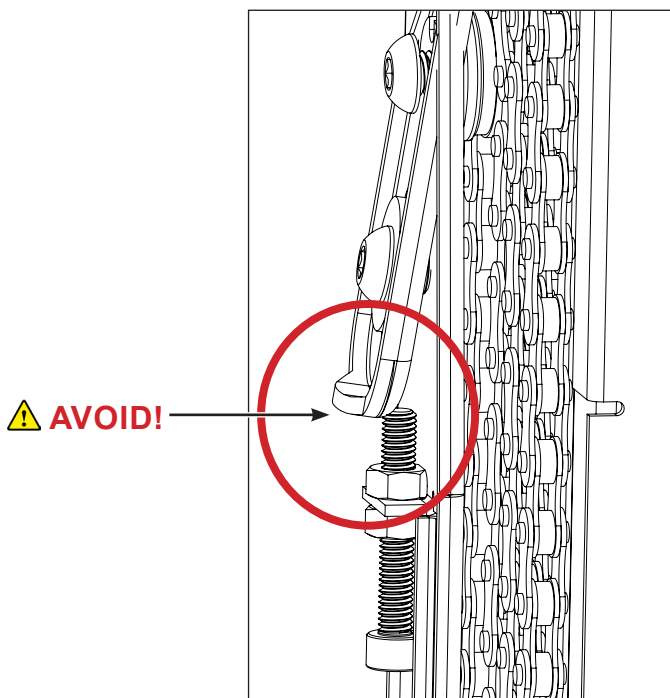

IMAGE 7

⚠ CAUTION

When executing step 8, make sure that the tensioner carriage stays in contact with the adjustment screw after each setting. To do so, place the extremity of a flat blade screwdriver on the bottom edge of the tensioner carriage and hit the top of the screwdriver with a hammer to eliminate the gap (see image 8).

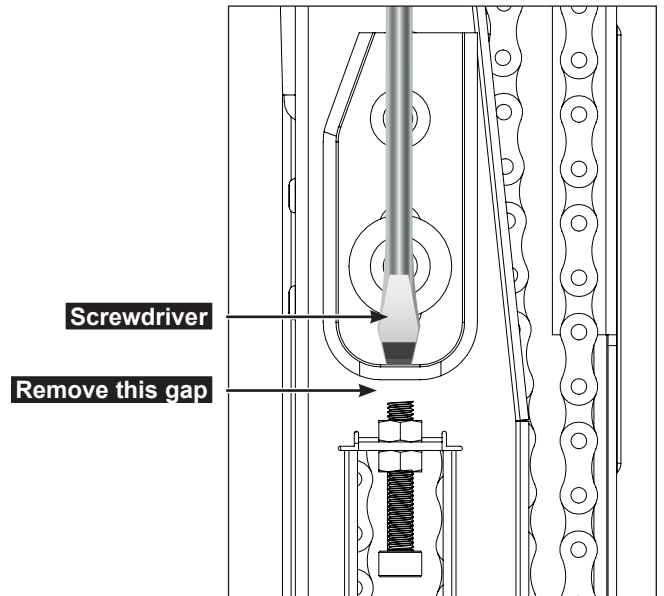

IMAGE 8

- 9) When the chain is tangent to the right side of the slot, secure the adjustment screw lock nut using the appropriate key.
- 10) Retighten the carriage locking screw with a 3/16" Allen key.
- 11) Bring down the sleeves of the post.

⚠ WARNING

Slowly bring the sleeves back down to prevent either hand injuries or damaging the unit.

- 12) Tighten the Phillips screw at the bottom of the post.
- 13) Operate the cover up and down twice, and put it back to its highest position.
- 14) Steps 2 to 13 MUST be repeated for the three other posts, one post at a time.
- 15) Put the key back in its key switch socket. Operate the spa cover normally to see if everything is correct. The previous steps should have resolved the bouncing issue of the cover. If the bouncing problem persists, call Covana for the Technical Support department.

IMPORTANT

Close the cover and reinstall the all-weather seals in their original position; i.e., in contact with the outer sleeve of every post.