

PRODUCT MODELS

- Evolution Cover with **G3 Posts** only
- Oasis Cover with **G3 Posts** only

PURPOSE OF THE REPAIR PROCEDURE

This repair procedure should be performed if the chain needs to be replaced on the Evolution or Oasis spa cover.

PREPARATION

- The cover must be closed.
- Make sure the parts kit is complete and that parts have not been damaged during transport. Call your local dealer if parts need to be replaced.
- Gather the required tools, as seen in the table at right.

TOOLS REQUIRED

7/32" Allen key	White grease spray	Measuring tape	
Phillips screwdriver	Flat blade screwdriver	Robertson screwdriver	
Round tip punch	36" long level	Hammer	Heat gun
Locking pliers	Utility knife		

PARTS KIT NO. 233456

1 x Chain	2 x Shrink tube
-----------	-----------------

Version française à la page 4.

⚠ CAUTION

Do not use power tools, some parts are fragile and may break under too much torque.

⚠ WARNING

This procedure must be performed by a certified Covana installer.

Keep the key out of the key switch socket at all times. The certified Covana installer must keep control of the key during the repair procedure. Derogation from this directive could cause serious injury or damage the cover.

NOTE

All images shown are for illustration purpose only. Actual product may vary due to the different models this procedure is intended for.

STEP BY STEP PROCEDURE

A- REMOVING THE DEFECTIVE CHAIN

- 1) Lower the cover (fully closed) and ensure it is sitting on the spa completely.

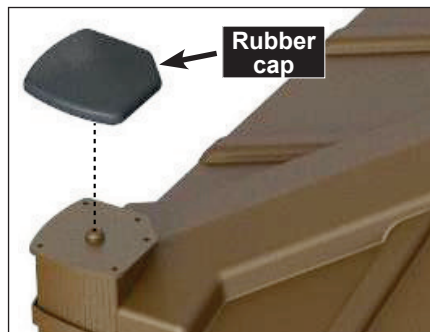

IMAGE 1

- 2) Remove the rubber cap from each post.

- 3) Remove the four M6 x 20 mm bolts and 5/16" painted metal washers from the defective post only.

Do not discard! Leave the bracket attached to the sleeve.

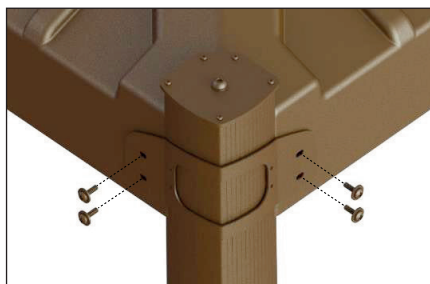

IMAGE 2

- 4) Remove the 3/8-24 x 1" Allen bolt with a 7/32" Allen key from the defective post only. **Do not discard!**



IMAGE 3

- 5) Loosen the Phillips M6 x 20 mm screw at the bottom of the defective post only. **Do not remove the screw.**

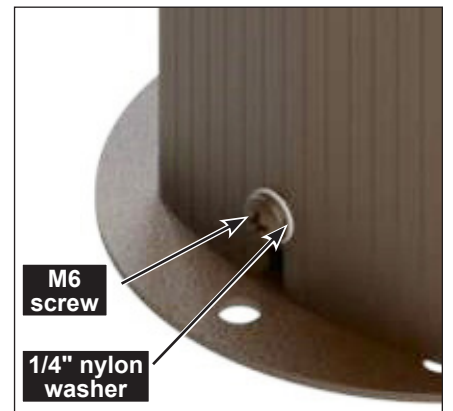

IMAGE 4

- 6) Slide the sleeves upward to expose the jack. Set them aside in a safe location.

- 7) Using a Robertson screwdriver, remove the five no. 8 x 3/4" screws from the top plate of the three other posts.
Do not discard!

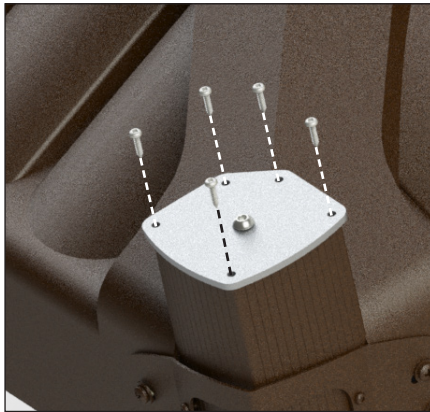

IMAGE 5

- 8) Using the key switch, extend the posts to their full height.

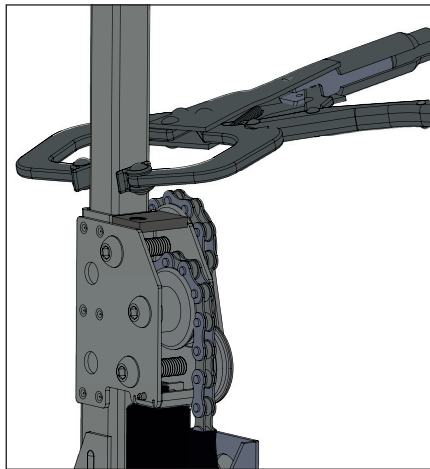

IMAGE 6

- 9) Place locking pliers on the inner tube of the defective jack only, and turn the key switch to lower the jack about 1". This will release the pressure on the chain.

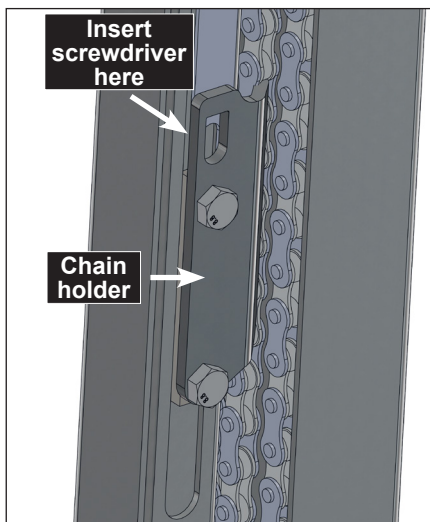

IMAGE 7

- 10) Cut the shrink tube at both ends of the defective chain.

Unhook the defective chain from the front of the jack (see image 8) and from the chain holder (image 7). **If need be**, use a flat blade screwdriver to slightly bend the top of the chain holder outwards, to help unhook the chain.

B- INSTALLING THE NEW CHAIN

- 1) Insert one of the shrink tubes on the new chain.
2) Run the new chain through the pulley and insert it in the chain holder (see image 7). Then, keeping the chain vertical, lower the shrink tube as close as possible to the end of the hook. Use a heat gun to apply heat to the tube. If need be, use a hammer and a round tip punch to carefully tap the top of the chain holder back in place.

- 3) Insert the second shrink tube on the chain. Then, insert the hook in the front of the jack and pull it up so it's properly seated. Lower the shrink tube as close as possible to the end of the hook. Use a heat gun to apply heat to the tube.

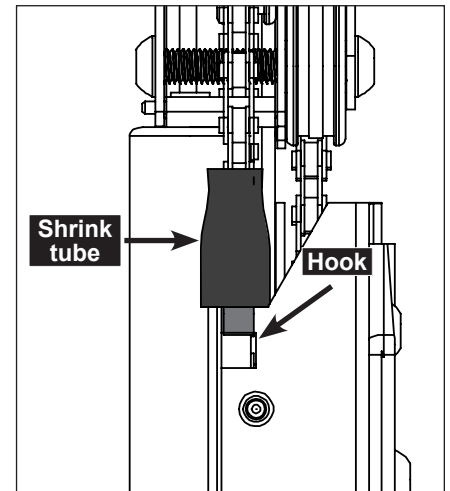

IMAGE 8

- 4) Using the key switch, elevate the cover to apply full pressure to the chain.

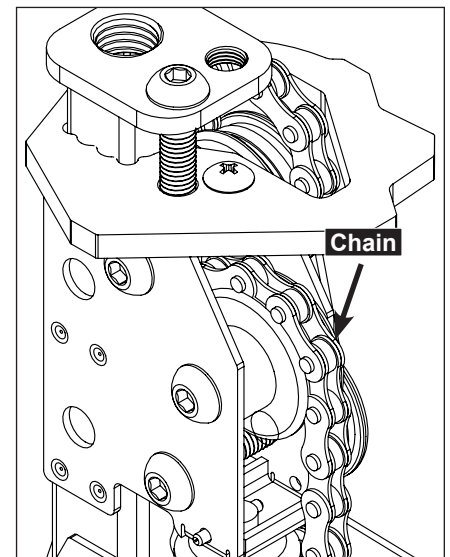

IMAGE 9

- 5) Remove the locking pliers.

NOTE

Since the four jacks are currently accessible, it is strongly suggested to grease all of them to ensure peak performance.

- 6) Ensure the cover is lowered completely and the jacks are extended to their full height.

- 7) For each jack, using white grease spray, lubricate all the mechanical components that are visible, especially the vertical tubes.



IMAGE 10

- 8) Use the key switch to lower the system completely.
- 9) Slide the sleeves over the jack. Be sure to align the opening at the bottom of the sleeves with the U-frame attached (see image 11).

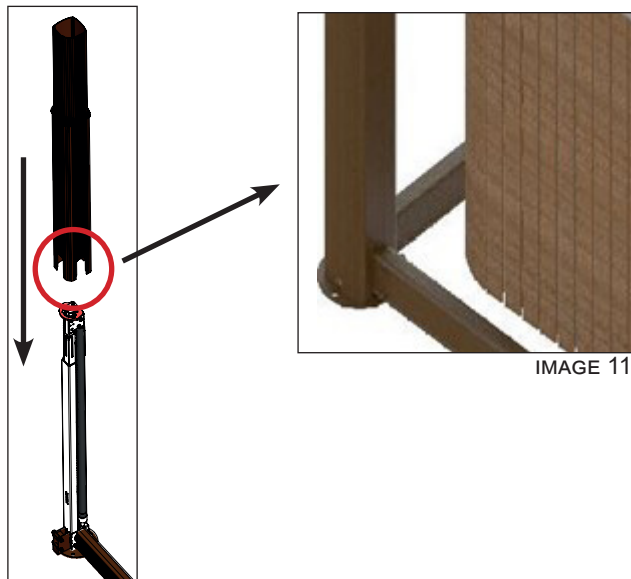

IMAGE 11

- 10) Tighten the Phillips M6 x 20 mm screw at the bottom of the post (see image 4).

CAUTION
Make sure that the nylon washer is located on the outside of the outer sleeve.

- 11) Make sure the all-weather seal on each post is slid all the way down against the outer sleeve.

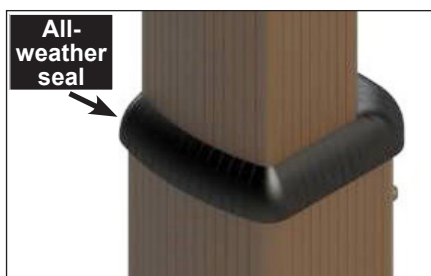

IMAGE 12

WARNING
Failing to properly position this seal may cause serious damage to the post mechanism.

- 12) Reinstall the 3/8-24 x 1" Allen bolt with the narrow part of the bushing facing downwards using a 7/32" Allen key on the post (see image 3).
- 13) Using a Robertson screwdriver, reinstall the three top plates with five no. 8 x 3/4" screws each (see image 5).
- 14) Ensure the cover is still centered. Use a measuring tape on all four sides. Also, verify whether all the posts are vertically leveled with a 36" level.

- 15) Fasten the corner bracket to the cover (following the order of installation illustrated at right) with four Phillips M6 x 20 mm bolts and 5/16" painted metal washers.

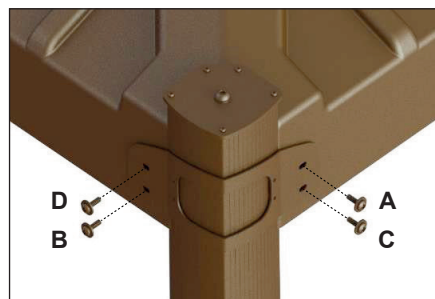

IMAGE 13

WARNING
Make sure the sleeve is correctly pressed against the outer shell before installing the M6 x 20 mm bolts.

- 16) Put the key back in its key switch socket. Verify the installation of the bracket by sliding the middle sleeve up and down by hand. Make sure it slides without scratching or interfering with the inner or outer sleeve. If all seems to function properly, lower the cover and check if the sleeves are level using a 36" level on both sides of the sleeves. If an interference occurs, look at all the parts that have been worked on and make sure there are no broken screws. Reviewing step 10 to retighten the M6 x 20 mm screw could help.
- 17) Install the rubber cap on each post (see image 1).
- 18) Operate the spa cover normally to see if everything is correct. If there is any issue with the cover, please refer to the troubleshooting section of the Owner's manual or call Covana for the Technical Support department.