

PRODUCT MODELS

- C-EP Cover with **G3 Posts** only
- Legend Cover with **G3 Posts** only

PURPOSE OF THE REPAIR PROCEDURE

This repair procedure should be performed if the chain needs to be replaced on the C-EP or Legend spa cover.

PREPARATION

- The cover must be closed.
- Make sure the parts kit is complete and that parts have not been damaged during transport. Call your local dealer if parts need to be replaced.
- Gather the required tools, as seen in the table at right.

TOOLS REQUIRED

5/32" Allen key	White grease spray	Hammer	Heat gun
Locking pliers	Flat blade screwdriver	Robertson screwdriver	
Round tip punch	36" long level	7/16" Socket wrench & spanner	
Utility knife			

PARTS KIT NO. 233456

1 x Chain	2 x Shrink tube
-----------	-----------------

Version française à la page 4.

⚠ CAUTION

Do not use power tools, some parts are fragile and may break under too much torque.

⚠ WARNING

This procedure must be performed by a certified Covana installer.

Never raise or lower the jack without it being attached to the cover.

STEP BY STEP PROCEDURE

A- REMOVING THE SLEEVE ASSEMBLY

- 1) Lower the cover (fully closed) and ensure it is sitting on the spa completely.
- 2) Use a Robertson screwdriver to remove the top plate of the defective post only by unscrewing both Robertson no. 8 self-drilling screws (see image 1).
- 3) Detach the bottom mount bracket arms from the tub mount bracket of the defective post only. Use a 5/32" Allen key with a 7/16" spanner to unscrew both 1/4-20 hex drive bolts located on the outside. Then, do the same for the top mount bracket (see image 2).

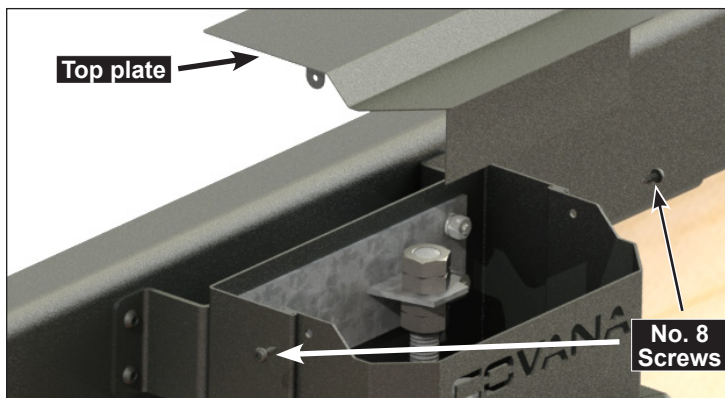

IMAGE 1

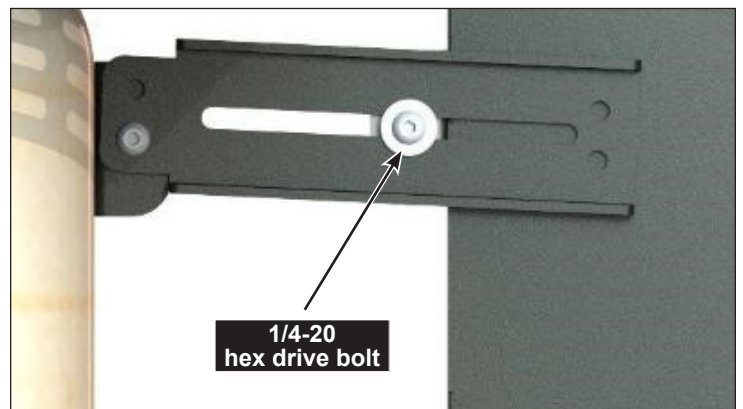

IMAGE 2

- 4) Untighten (**do not remove**) both 1/4-20 hexagonal bolts at the bottom of the sleeve of the defective post only. Use a 7/16" socket wrench or spanner if there is not enough space (see image 3).

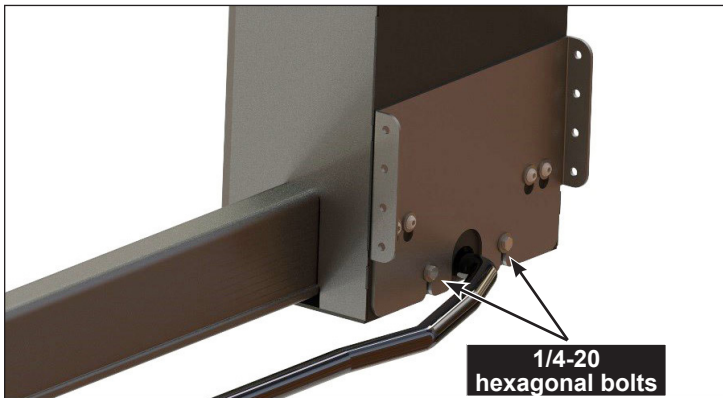

IMAGE 3

- 5) Use a 7/16" socket wrench to unfasten the sleeve from the post mount bracket by unscrewing the four 1/4-20 x 3/4" carriage bolts (see image 4).

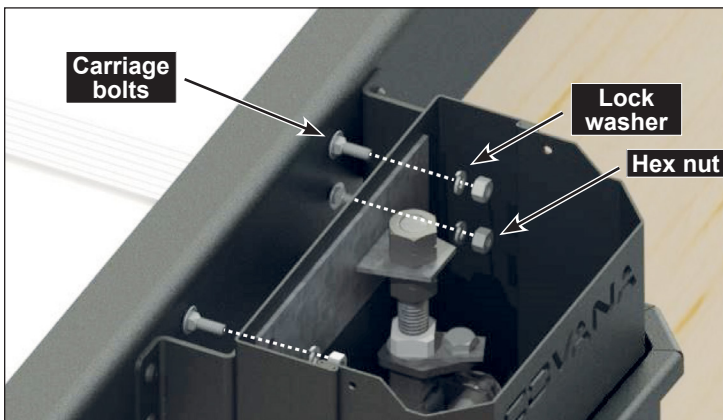

IMAGE 4

- 6) Slide the sleeve assembly (Inner/Middle/Outer sleeves) upward and lay it on a clean flat surface.

⚠ WARNING
Slowly and gently pull up the sleeves to prevent injuries.

- 7) Use a 7/16" socket wrench and spanner to fasten the jack adapter to the post mount bracket using the four previously removed 1/4-20 x 3/4" carriage bolts, 1/4" lock washers, and 1/4" hex nuts (see image 5).

⚠ WARNING
Never raise or lower the jack without it being attached to the cover.

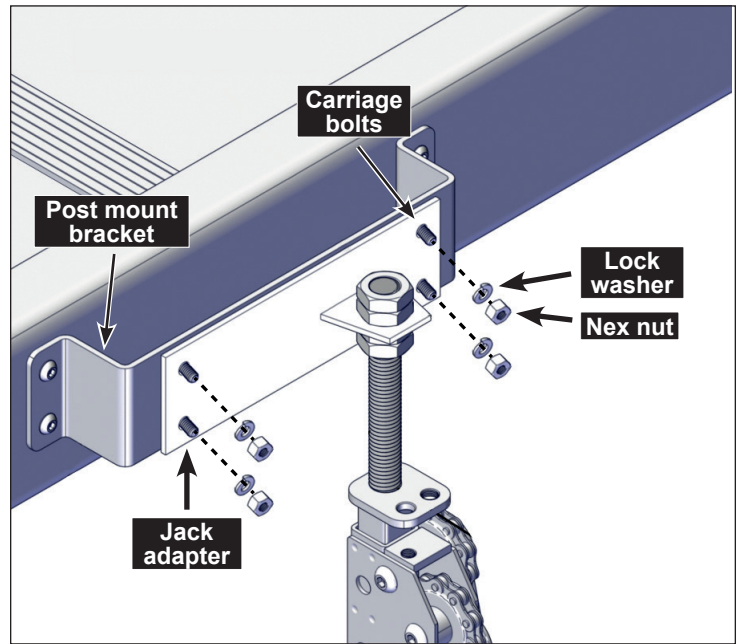

IMAGE 5

- 8) Using the key switch, extend the posts to their full height.

- 9) Place locking pliers on the inner tube of the defective jack only, and turn the key switch to lower the jack about 1". This will release the pressure on the chain.

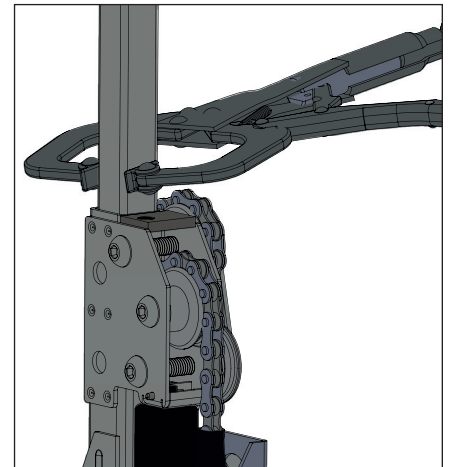

IMAGE 6

- 10) Cut the shrink tube at both ends of the defective chain.

Unhook the defective chain from the front of the jack (see image 8) and from the chain holder (image 7). **If need be**, use a flat blade screwdriver to slightly bend the top of the chain holder outwards, to help unhook the chain.

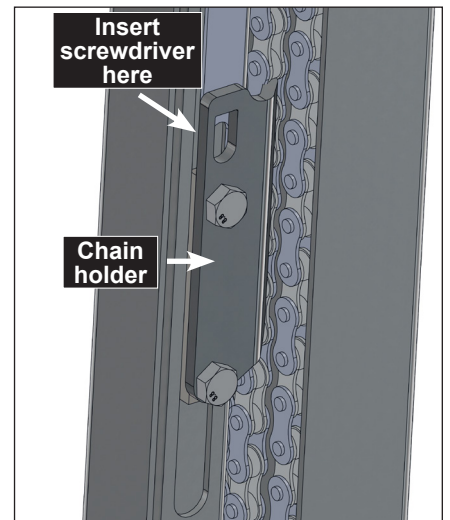

IMAGE 7

B- INSTALLING THE NEW CHAIN

- 1) Insert one of the shrink tubes on the new chain.
- 2) Run the new chain through the pulley and insert it in the chain holder (see image 7). Then, keeping the chain vertical, lower the shrink tube as close as possible to the end of the hook. Use a heat gun to apply heat to the tube. If need be, use a hammer and a round tip punch to carefully tap the top of the chain holder back in place.

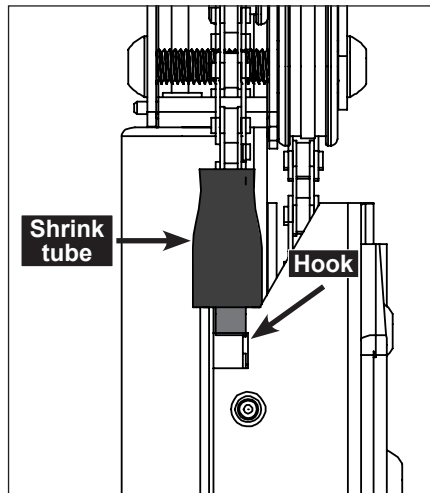

IMAGE 8

- 3) Insert the second shrink tube on the chain. Then, insert the hook in the front of the jack and pull it up so it's properly seated. Lower the shrink tube as close as possible to the end of the hook. Use a heat gun to apply heat to the tube.

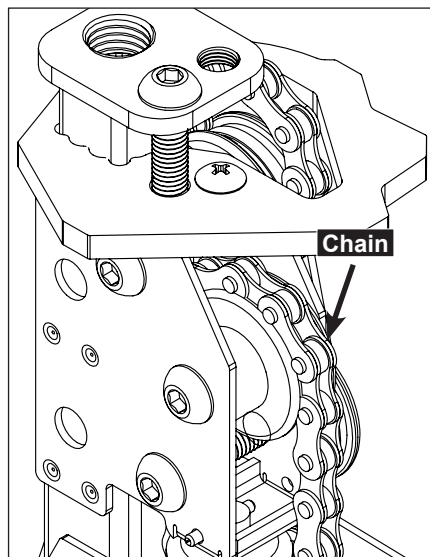

IMAGE 9

- 4) Using the key switch, elevate the cover to apply full pressure to the chain.

- 5) Remove the locking pliers.

NOTE

Since the jack is currently accessible, it is strongly suggested to grease it to ensure peak performance.

- 6) Using white grease spray, lubricate all the mechanical components of the jack that are visible, especially the vertical tubes.

C- REINSTALLING THE SLEEVE ASSEMBLY

- 1) Use the key switch to lower the cover completely.
- 2) Use a 7/16" socket wrench and spanner to unfasten the jack adapter from the post mount bracket (see image 5).
- 3) Slide the sleeves over the top of the jack and fasten them to the post mount bracket using the 1/4-20 x 3/4" carriage bolts, 1/4" lock washers, and 1/4" hex nuts. Use a 7/16" socket wrench and spanner (see image 4).
- 4) Retighten the 1/4-20 hexagonal bolts at the bottom of the sleeves. Use a 7/16" socket wrench or spanner if there's not enough space. Ensure that the washer is outside of the outer sleeve. This will ensure the sleeve is held correctly (see image 3).

⚠ WARNING

Slowly bring the sleeves back down to prevent either hand injuries or damaging the unit.

- 5) Use a 5/32" Allen key and 7/16" spanner to attach the top mount bracket arms to the tub mount bracket using the 1/4-20 hex drive bolt and 1/4" flat washer on the outside. Use a 1/4" lock washer and 1/4-20 nut on the inside. Then, do the same for the bottom mount bracket (see image 2).

- 6) Use a 36" level to make sure the post is still level in both axes. If not, unscrew the mount arms and reposition the sleeve. Use the outer sleeve as a reference.



IMAGE 11

- 7) Use both previously removed Robertson no. 8 x 1/2" self-drilling screws to attach the top plate on the post (see image 1).
- 8) Operate the spa cover normally to see if everything is correct. If there is any issue with the cover, please refer to the troubleshooting section of the Owner's manual or call Covana for the Technical Support department.